

SPSX

SPSX SERIES SINGLE POINT STAINLESS STEEL LOAD CELLS



Stainless steel load cells for off center loads, suitable for example to build CE-M approved scales with a single load cell with maximum dimensions of 600x800 mm.

CAPACITIES (kg): 100, 300, 500.

OIML R60. C3 precision class.

17-4 PH stainless steel. **IP67** protection.

Working in cooperation with:

UAB DESKA

PRAMONES 5 - LT-94102 - KLAIPEDA - LITHUANIA
Tel. 00370-46-381089 Fax. 00370-445-76466
info@deska.lt

The best solution
for advanced industrial
applications

MAIN FEATURES

- C3 PRECISION CLASS
- OFF CENTER LOAD COMPENSATED
- MADE IN 17-4 PH STAINLESS STEEL
- IP67 PROTECTION
- MAX. CAPACITIES FROM 100 TO 500 kg
- FOR PLATFORMS WITH DIMENSIONS UP TO 600 X 800 mm
- SHIELDED CONNECTION CABLE
- TEST CERTIFICATE AVAILABLE UPON REQUEST

TECHNICAL FEATURES

- Minimum load cell verification interval: $V_{min} = E_{Max} / 15.000$
- Maximum number of verification intervals: $n_{LC} = 3000$
- Full Scale Output: 2mV/V +/- 10%
- Temperature effect on zero: 0,01% FS/10K
- Temperature effect on full scale output: 0,001% FS/10K
- Compensated Temperature Range: -10°C/+40°C
- Operating Temperature Range: -10°C/+50°C
- Creep at nominal load in 30 minutes: $\pm 0,01\%$ F.S.
- Maximum tolerated excitation voltage: 15 VDC
- Input Resistance: 390 ± 15 Ohm
- Output Resistance: 359 ± 5 Ohm
- Insulation Resistance (100V) >1000 MOhm
- Safe Overload: 300% F.S.
- Ultimate Overload: 300% F.S.
- Nominal displacement: < 0.5 mm
- 6-wire shielded cable, 3m long, 5mm diameter

ATEX Version

- The CCATEX certificate makes the load cell suitable for use in hazardous areas with protection methods according to:
ATEX II 1G Ex ia IIC T6 (Ta -20÷+40°C) TX (Ta -20÷+65°C) Ga
ATEX II 1D Ex ta IIIC TX°C (Ta -20÷+40°C) TX°C (Ta -20÷+65°C) Da IP65.
The certificate includes the manual and the ATEX CE conformity declaration (available in EN, DE, FR, and IT).
- **IMPORTANT:** the certificate refers to the single load cell. For systems with more load cells, it is necessary to order one certificate for each load cell.

DETAIL 1

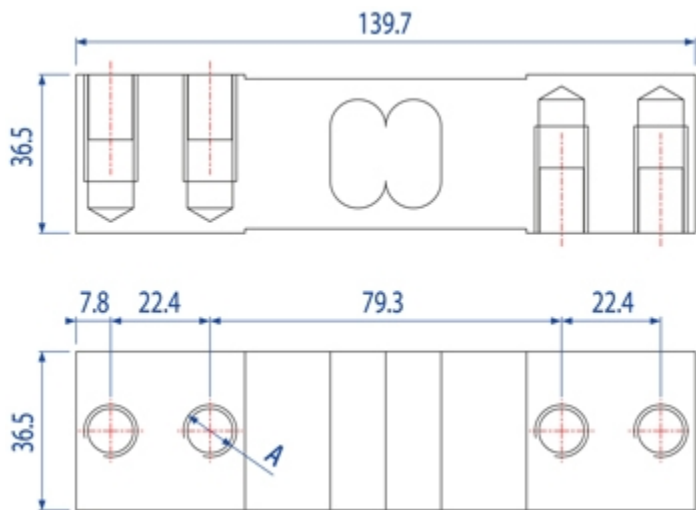



Code	Dimensions in mm
	A
SPSX300	M10
SPSX500	M12

Wiring Code	
<i>Colour</i>	<i>Function</i>
WHITE	OUTPUT +
GREEN	SENSE +
BLUE	INPUT +
RED	OUTPUT -
BLACK	INPUT -
GREY	SENSE -

VERSIONS

Available versions

Codice	Piatto Max (mm)	Max (kg)
SPSX100 	600 x 800	100
SPSX300 	600 x 800	300
SPSX500 	600 x 800	500



www.diniargeo.com



“YOUR WORLDWIDE PARTNER FOR WEIGHING,”

DINI ARGEO
FRANCE sarl
Nogent-sur-Marne

DINI ARGEO
GMBH
Sinsheim - Germany

DINI ARGEO
UK Ltd
Taunton - United Kingdom

DINI ARGEO WEIGHING
INSTRUMENTS Ltd
Shanghai - China

DINI ARGEO
WEIGHBRIDGES
Calto (RO) – Italy



HEAD OFFICE
Via Della Fisica, 20
41042 Spezzano di Fiorano Modena - Italy



UAB DESKA

PRAMONES 5 - LT-94102 - KLAIPEDA - LITHUANIA

Tel. 00370-46-381089 Fax. 00370-445-76466

info@deska.lt

SALES AND TECHNICAL ASSISTANCE SERVICE